

GGB-SHB™ CASE HARDENED STEEL BEARINGS

For Lubricated Applications



The Global Leader
in High Performance Bearing Solutions



an EnPro Industries company

GGB Bearing Technology

GGB's history as the global leader in plain bearing technologies dates back more than 115 years, beginning with the founding of Glacier Antifriction Metal Company in 1899. GGB introduced the industry-leading DU® bearing in 1965. Since that time, GGB has continued to create innovative technologies and solutions that improve safety, performance and profitability in a wide range of markets. Today, our products can be found everywhere – from scientific vessels at the bottom of the ocean to racecars speeding down the tarmac to jumbo jets slicing through the sky to the Curiosity rover exploring the surface of Mars.

Throughout our history, safety, excellence and respect have formed the foundational values for the entire GGB family. They are of paramount importance as we seek to maximize personal possibility, achieve excellence and establish open, creative work environments with the highest safety standards in the industry.

- **Safety:** GGB's deep-rooted culture of safety places a relentless focus on creating a secure, healthy work environment for all. A core value of GGB, safety is critically essential at all levels of business in order to achieve our goal of having the safest employees in the industry.
- **Excellence:** A world-class organization is built by fostering excellence throughout the company in all positions and functional areas. Our world-class manufacturing plants are certified in quality and excellence in the industry according to ISO 9001, TS 16949, ISO 14001, ISO 50001 and OHSAS 18001, allowing us to access the industry's best practices while aligning our quality management system with global standards.
- **Respect:** We believe that respect is consistent with the growth of individuals and groups. Our teams work together with mutual respect regardless of background, nationality or function, embracing the diversity of people and learning from one another.

The GGB Advantage

With manufacturing facilities around the world, including cutting edge R&D facilities, flexible production platforms and extensive customer support networks, GGB offers unmatched technical expertise combined with razor sharp responsiveness and customized solutions. Our global presence and local logistics networks ensure our customers receive only the highest quality bearing solutions, in a timely manner and with extensive engineering support.

We don't just make products, we build partnerships. That's the GGB Advantage.

Quality

Our world-class manufacturing plants in the United States, Brazil, China, Germany, France and Slovakia are **CERTIFIED IN QUALITY AND EXCELLENCE IN THE INDUSTRY** according to ISO 9001, TS 16949, ISO 14001, ISO 50001 and OHSAS 18001. This allows us to access the industry's best practices while aligning our quality management system with global standards.

For a complete listing of our certifications, please visit our website:

www.ggbearings.com/en/company/certificates

Content

	GGB History	4
1	Introduction	6
2	Applications	6
3	Characteristics and Advantages ..	8
3.1	Characteristics	8
3.2	Advantages	8
4	Available Forms	9
	Standard Cylindrical Bearings	9
	Special Bearings	9
5	Bearing Properties	10
6	Dimensions	11
6.1	Standard Range	11
6.2	Standard Tolerances	12
7	Assembly	13

Bearing Application Data Sheet ..	14
Product Information	15



The Highest Standards in Quality

Our world-class manufacturing plants in the United States, Brazil, China, Germany, France and Slovakia are certified in quality and excellence according to ISO 9001, TS 16949, ISO 14001, ISO 50001 and OHSAS 18001. This allows us to access the industry's best practices while aligning our management system with global standards.

For a complete listing of our certifications, please visit our website:
www.ggbearings.com/en/company/certificates

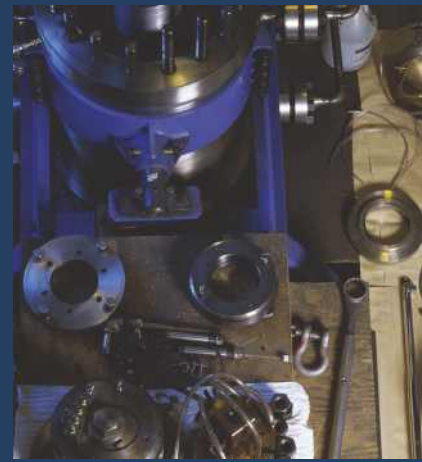

A Long History of Innovation

From our modest beginnings over 115 years ago, GGB grew through innovation and technical expertise to become the world's leading manufacturer of plain bearing solutions.

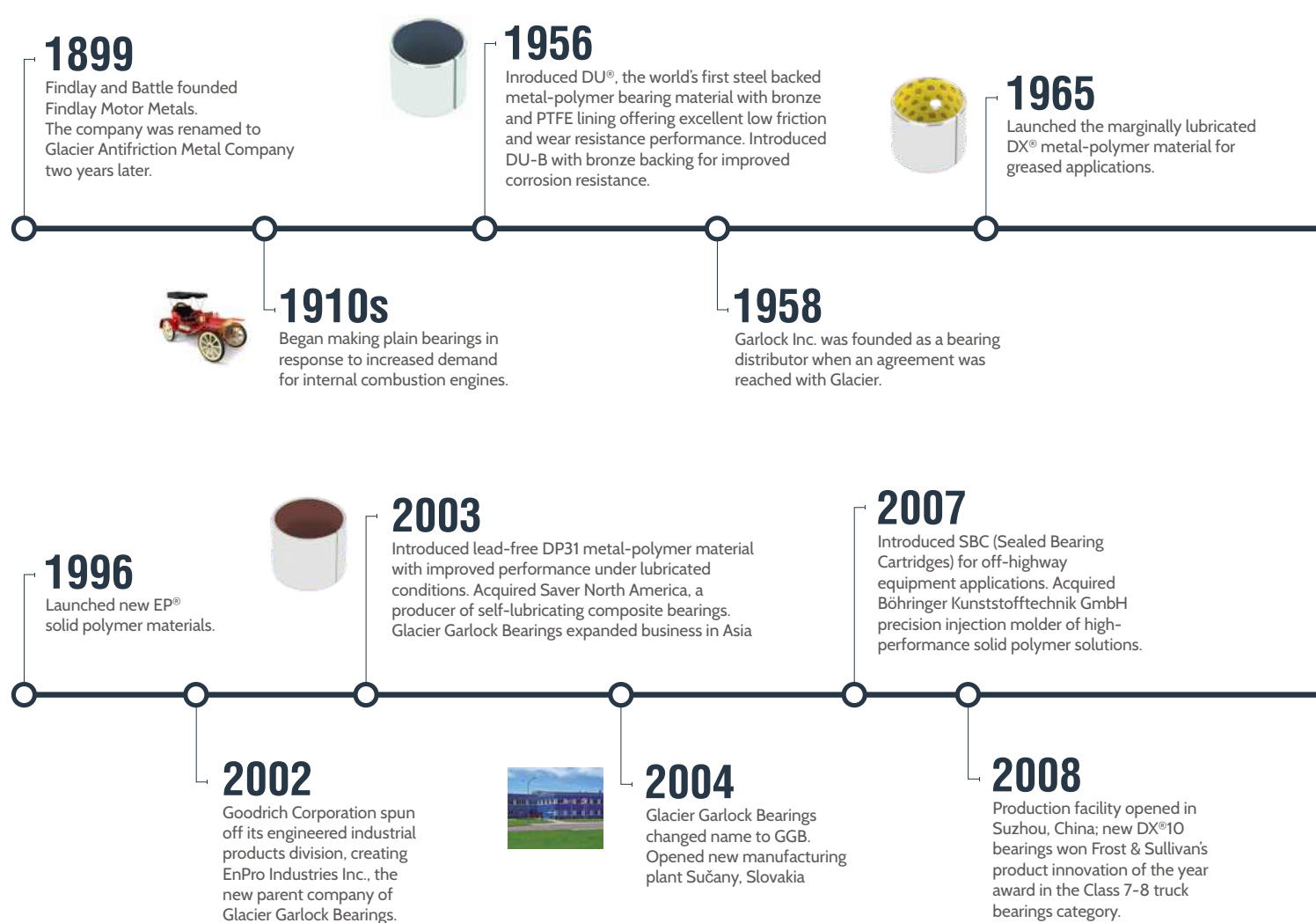



1974

Began continuous casting of the SICAL® range of aluminum alloys and high precision machining of bushing blocks in Dieuze, France.

1978

Introduced filament wound product range in the USA, including GAR-MAX®.



1995

Introduced lead-free steel backed DP4® metal-polymer material for automotive shock absorbers and other hydraulic applications. Introduced DP4-B with bronze backing for improved corrosion resistance.



1970s

Glacier licensed technology to a number of overseas bearing manufacturers. Licenses included: SIC (France), Garlock Bearings (USA).

1976

Glacier and Garlock Inc. established joint venture company Garlock Bearings Inc.



1986

Launched HI-EX™ metal-polymer material, designed for high temperature applications.

2009

Filament-wound product range introduced to the European and Asian markets; GGB North America certified to AS9100B, the aerospace industry's standard for quality management systems.

2011

Acquired PI Bearing Technologies, now GGB Chicago, a producer of PICAL® aluminum alloy bushing blocks for demanding fluid power applications. GGB plants certified to OHS18001 for health and safety management systems.

2013

Launched new self-lubricating metallic bearing materials GGB-CSM® and GGB-CBM® as well as FLASH-CLICK® two-piece, double-flanged solid polymer bearings.



2014

Series of self-lubricating sintered bronze and sintered iron bearings introduced, including GGB-BP25, GGB-FP20 and GGB-SO16.

Three plants mark milestone anniversaries: 40 years for Heilbronn, Germany and Dieuze, France and 10 years for Sučany, Slovakia.

2010

Introduced lead-free DP10 and DP11 metal-polymer materials for superior performance under marginally lubricated and dry running conditions.

2012

DTS10® machinable metal-polymer bearings are launched for the fluid power and compressor markets. GGB bearings land on Mars aboard NASA's Curiosity rover.



2015

Introduced HPMB®, a fully machinable, made-to-order filament wound bearing material.

Also introduced the lead-free GGB-SZ, for high specific loads with low-frequency, oscillating motion.



2016

Introduced GGB-SHB™ case hardened steel bearings



1 Introduction

The continuous improvements made in today's machinery and equipment are heavily dependent on the performance of the bearings.

The bearings are expected to perform under increasingly difficult operating conditions and still offer greater reliability, a longer service life with reduced maintenance and a lower cost of ownership.

GGB brings more than 115 years of experience and accumulated expertise in self-lubricating bearings, offering an extensive portfolio of bearing products and and technical application knowledge across a wide range of industries. Our application engineering team can provide assistance in:

- Selection of the optimal type of bearing for your application
- Design with either standard or custom products
- Calculation of estimated life expectancy
- Assembly and installation

GGB offers the most advanced bearing products in the industry, supported by laboratory testing in state-of-the-art facilities, produced according to the highest quality standards.

This brochure gives information about GGB-SHB™ case hardened steel bearings that ideally suited to applications with harsh working conditions. Thanks to their characteristics, they are usually employed as a protection against wear on all coupling systems having a low rotation speed combined with a high specific pressure, where bearings, shafts, pins and coupling bolts can be easily replaced.

2 Applications

GGB-SHB™ case hardened steel bearings are perfectly suited to a wide range of applications, including:

- Earth moving machinery, excavators and loaders
- Farming machinery, power harrows, ploughs and harvesters
- Grabs, buckets and grippers
- Hydraulic cylinders for the protection against wear of bottoms and eyelets
- Industrial washing machines
- Sliding guides for industrial presses
- Suction pumps, sliding seats
- Machine tools



3 Characteristics and Advantages

3.1 Characteristics

Standard Products

- Steel 20MnV6, ASTM A381, DIN 1.5217
- Outer diameters from Ø 30 mm to Ø 100 mm
- Tolerances: Outer diameter u6 / Inner diameter C8
- Case hardening and tempering treatment
- Case hardening depth 0.8 - 1.0 mm
- Surface hardness HRC 58 - 62
- Over 60 000 bearings available in stock

Special Products

- Other materials are available to order
- Outer diameters up to 250 mm are feasible

3.2 Advantages

The advantages gained from mounting GGB-SHB™ bearings are as follows:

- Special steel alloy containing manganese and vanadium for higher bearing strength, toughness and wear resistance
- Carburized case-hardened and tempered bearing surface for improved resistance to wear, to seizure and to fatigue damage under dynamic/shock loads
- Uniform heat treatment process and continuous quality checks to ensure the preset carburizing depth
- Tracability of the chemical and mechanical properties of each production batch for high product quality

4 Available Forms

Standard Cylindrical Bearings

Available with various grease grooves and holes, with hardening and tempering treatment.



Special Bearings

Available with various grease grooves, holes, and in flanged configuration.



5 Bearing Properties



Bearing Properties		Imperial Units	Imperial Value	Metric Units	Metric Value
General					
Maximum load p	Static	psi	43 500	N/mm ²	300
	Dynamic	psi	21 500	N/mm ²	150
Tensile strength		psi	79 750	N/mm ²	550
Maximum operating temperature		°F	302	°C	150
Density			0.282		7.8
Coefficient of linear thermal expansion		10 ⁻⁶ /F	6,67	10 ⁻⁶ /K	12
Grease lubricated					
Maximum sliding speed U		fpm	19.7	m/s	0.1
Maximum pU factor		psi x fpm	42 000	N/mm ² x m/s	1.5
Coefficient of friction f			0.2		0.2
Mating Material					
Bearing surface roughness, Ra		µin	≤ 31.5	µm	≤ 0.8
Bearing surface hardness		HRC	58 - 62	HRC	58 - 62

Operating Performance	
Dry	Not recommended
Oil lubricated	Good
Grease lubricated	Very good
Water lubricated	Not recommended
Process fluid lubricated	Depending on fluid

Microsection



Steel E410, E470
(20MnV6, AISI A381)
acc. to EN 10305

6 Dimensions

6.1 Standard GGB-SHB™ Bearings

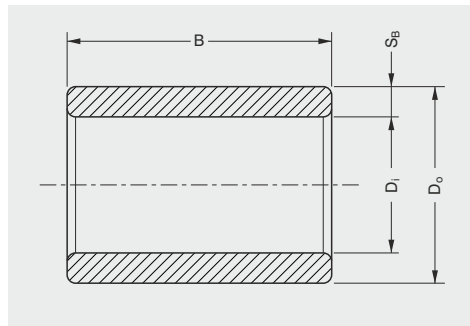

Dimensions of standard cylindrical GGB-SHB™ case hardened steel bearings [mm]																		
Inner Ø D _i	Outer Ø D _o	Wall thick- ness S _B	Width B															
			20	25	30	35	40	45	50	55	60	65	70	75	80	85	90	95
20	30	5.0	●	●	●	●	●	●	●	●	●	●	●	●	●	●	●	●
25	35		●	●	●	●	●	●	●	●	●	●	●	●	●	●	●	●
30	38	4.0			●	●	●	●	●	●	●	●	●	●	●	●	●	●
30	40	5.0			●	●	●	●	●	●	●	●	●	●	●	●	●	●
35	45		●	●	●	●	●	●	●	●	●	●	●	●	●	●	●	●
40	50		●	●	●	●	●	●	●	●	●	●	●	●	●	●	●	●
45	55		●	●	●	●	●	●	●	●	●	●	●	●	●	●	●	●
50	60		●	●	●	●	●	●	●	●	●	●	●	●	●	●	●	●
55	65				●	●	●	●	●	●	●	●	●	●	●	●	●	●
60	70					●	●	●	●	●	●	●	●	●	●	●	●	●
65	75					●	●	●	●	●	●	●	●	●	●	●	●	●
70	80					●	●	●	●	●	●	●	●	●	●	●	●	●
75	85					●	●	●	●	●	●	●	●	●	●	●	●	●
80	90					●	●	●	●	●	●	●	●	●	●	●	●	
85	95						●	●	●	●	●	●	●	●	●	●	●	
90	100							●	●	●	●	●	●	●	●	●	●	

Table: Dimensions of standard cylindrical GGB-SHB™ case hardened steel bearings

6.2 Standard Tolerances

The standard range of GGB-SHB™ bearings are supplied with:

- outer and inner diameter tolerances of u6 and C8 respectively
- a casehardened depth of 0.8 - 1.0 mm
- a surface hardness of HRC 58-62

The case hardening and tempering treatment enhances the bearing's strength and resistance to wear enabling operation in the most arduous applications. The low surface roughness of the bearing reduces friction for improved efficiency. After initial greasing, relubrication intervals of up to 550 hours are possible (interval that can vary depending on the working conditions).

GGB-SHB™ bearings are available in standard sizes (see table on page 11) and, in most cases, are available from stock. Customized bearings designed by GGB or according to customer drawings can be produced and are made to order.

The bushes are marked with an identifiable marking for full traceability.

Tolerances of standard cylindrical GGB-SHB™ case hardened steel bearings							
Outside Ø D _o [mm]	Tolerance u6 [µm]	Inside Ø D _i [mm]	Tolerance C8 [µm]	Outside Ø D _o [mm]	Tolerance u6 [µm]	Inside Ø D _i [mm]	Tolerance C8 [µm]
> 24 ≤ 30	+ 61 + 48	> 18 ≤ 30	+ 143 + 110	> 100 ≤ 120	+ 166 + 144	> 100 ≤ 120	+ 234 + 180
> 30 ≤ 40	+ 76 + 60	> 30 ≤ 40	+ 159 + 120	> 120 ≤ 140	+ 195 + 170	> 120 ≤ 140	+ 263 + 200
> 40 ≤ 50	+ 86 + 70	> 40 ≤ 50	+ 169 + 130	> 140 ≤ 160	+ 215 + 190	> 140 ≤ 160	+ 273 + 210
> 50 ≤ 65	+ 106 + 87	> 50 ≤ 65	+ 186 + 140	> 160 ≤ 180	+ 235 + 210	> 160 ≤ 180	+ 293 + 230
> 65 ≤ 80	+ 121 + 102	> 65 ≤ 80	+ 196 + 150	> 180 ≤ 200	+ 265 + 236	> 180 ≤ 200	+ 312 + 240
> 80 ≤ 100	+ 146 + 124	> 80 ≤ 100	+ 224 + 170	> 200 ≤ 225	+ 287 + 258	> 200 ≤ 225	+ 332 + 260

Table: Tolerances of standard cylindrical GGB-SHB™ case hardened steel bearings

7 Assembly

Under normal conditions, it is recommended that the bearing is mounted with an interference fit into the housing to avoid movement of the bearing during operation.

GGB-SHB™ bearings can be assembled into the housing by using the following methods.

1) Assembly with a press

The GGB-SHB™ bearing can be inserted into the housing by using an appropriate tool and press.

2) Assembly with liquid nitrogen

Submerging the GGB-SHB™ bearing into liquid nitrogen sufficiently reduces the bearing outer diameter to enable an easy insertion of the bearing into the housing.

Recommended tolerances for the housing and the shaft				
Housing Ø D _{housing} [mm]	Tolerance H7 [µm]	Tolerance H8 [µm]	Pin Ø D _{pin} [mm]	Tolerance h7 [µm]
> 18 ≤ 30	+ 21 + 0	+ 33 + 0	> 18 ≤ 30	0 - 21
> 30 ≤ 50	+ 25 + 0	+ 29 + 0	> 30 ≤ 50	0 - 25
> 50 ≤ 80	+ 30 + 0	+ 46 + 0	> 50 ≤ 80	0 - 30
> 80 ≤ 120	+ 35 + 0	+ 54 + 0	> 80 ≤ 120	0 - 35
> 120 ≤ 180	+ 40 + 0	+ 63 + 0	> 120 ≤ 180	0 - 40
> 180 ≤ 250	+ 46 + 0	+ 72 + 0	> 180 ≤ 250	0 - 46

Table: Recommended tolerances for the housing and the shaft

By following the recommended tolerances indicated in the above table:

- Inner diameter tolerance H7 or H8 of the housing obtained by reaming
- Bearing outer diameter and inner diameter tolerances of u6 and C8 respectively

a clearance of approximately 80µm will be obtained between the bearing and the shaft.

This clearance is sufficient to allow a correct distribution of the lubricant in the bearing whilst ensuring a precise guidance of the shaft.

Bearing Application Data Sheet

Not sure which GGB part fits your application requirements? Go to ggbpartfinder.com to complete a Bearing Application Data Sheet online, and one of our GGB bearing specialists will reach out to you with recommended options that meet your application requirements. You can also complete the form below and share it with your GGB sales person or distributor representative.

DATA FOR BEARING DESIGN CALCULATION

Application: _____

Project / No.: _____ Quantity: _____ New Design Existing Design

DIMENSIONS (mm)

Inside diameter	D_i	
Outside diameter	D_o	
Length	B	
Flange diameter	D_{fl}	
Flange thickness	B_{fl}	
Wall thickness	S_T	
Length of slide plate	L	
Width of slide plate	W	
Thickness of slide plate	S_s	

LOAD

Radial load F	static [N]	
	dynamic [N]	
Axial load F	static [N]	
	dynamic [N]	
Specific load ρ	radial [MPa]	
	axial [MPa]	

MOVEMENT

Rotational speed	N [1/min]	
Speed	U [m/s]	
Length of stroke	L_s [mm]	
Frequency of stroke	[1/min]	
Oscillating cycle	ϕ [°]	
Osc. frequency	N_{osz} [1/min]	

MATING SURFACE

Material		
Hardness	HB/HRC	
Surface finish	Ra [μm]	

CUSTOMER INFORMATION

Company _____
 Street _____
 City / State / Province / Post Code _____
 Telephone _____ Fax _____
 Name _____
 Email Address _____ Date _____

FITS & TOLERANCES

Shaft	D_j	
Bearing housing	D_H	

OPERATING ENVIRONMENT

Ambient temperature	T_{amb} [°]	
<input type="checkbox"/>	Housing with good heating transfer properties	
<input type="checkbox"/>	Light pressing or insulated housing with poor heat transfer properties	
<input type="checkbox"/>	Non metal housing with poor heat transfer properties	
<input type="checkbox"/>	Alternate operation in water and dry	

LUBRICATION

<input type="checkbox"/>	Dry	
<input type="checkbox"/>	Continuous lubrication	
<input type="checkbox"/>	Process fluid lubrication	
<input type="checkbox"/>	Initial lubrication only	
<input type="checkbox"/>	Hydrodynamic conditions	
Process fluid		
Lubricant		
Dynamic viscosity	η	

SERVICE HOURS PER DAY

<input type="checkbox"/>	Continuous operation	
<input type="checkbox"/>	Intermittent operation	
Operating time		
Days per year		

SERVICE LIFE

Required service life	L_H [h]	
-----------------------	-----------	--

BEARING TYPE:

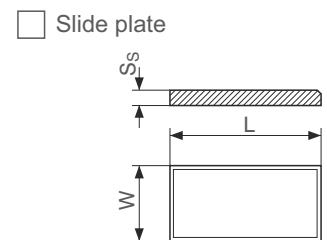
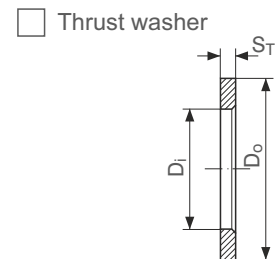
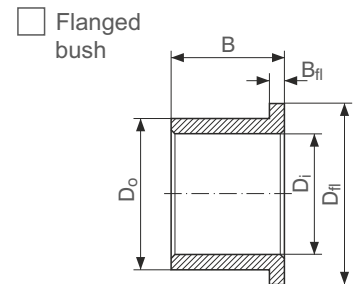
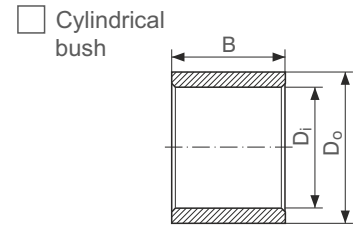

- Special parts (sketch)
- Steady load
- Rotating load
- Rotational movement
- Oscillating movement
- Linear movement

Product Information

GGB gives an assurance that the products described in this document have no manufacturing errors or material deficiencies.

The details set out in this document are registered to assist in assessing the material's suitability for the intended use. They have been developed from our own investigations as well as from generally accessible publications. They do not represent any assurance for the properties themselves.

Unless expressly declared in writing, GGB gives no warranty that the products described are suited to any particular purpose or specific operating circumstances. GGB accepts no liability for any losses, damages or costs however they may arise through direct or indirect use of these products.

GGB's sales and delivery terms and conditions, included as an integral part of quotations, stock and price lists, apply absolutely to all business conducted by GGB. Copies can be made available on request.

Products are subject to continual development. GGB retains the right to make specification amendments or improvements to the technical data without prior announcement.

Edition 2016 (This edition replaces earlier editions which hereby lose their validity).

Statement Regarding Lead Content in GGB Products & EU Directive Compliance

GGB is committed to adhering to all U.S., European and international standards and regulations with regard to lead content. We have established internal processes that monitor any changes to existing standards and regulations, and we work collaboratively with customers and distributors to ensure that all requirements are strictly followed. This includes RoHS and REACH guidelines.

GGB makes it a top priority to operate in an environmentally conscious and safe manner. We follow numerous industry best practices, and are committed to meeting or exceeding a variety of internationally recognized standards for emissions control and workplace safety.

Each of our global locations has management systems in place that adhere to ISO TS 16949, ISO 9001, ISO 14001, ISO 50001 and OHSAS 18001 quality regulations.

All of our certificates can be found here: <http://www.ggbearings.com/en/company/certificates>. A detailed explanation of our commitment to REACH and RoHS directives can be found at www.ggbearings.com/en/company/quality-and-environment.



an EnPro Industries company

The Global Leader in High Performance Bearing Solutions

GGB North America

700 Mid Atlantic Parkway
Thorofare, New Jersey, 08086 USA
Tel. +1-856-848-3200 • Fax +1-856-848-5115
email: usa@ggbearings.com • www.ggbearings.com



IN605ENG04-16USA