

GGB METAFRAM Range

Self-lubricating Sinter Bronze and Sinter Iron Bearing Solutions

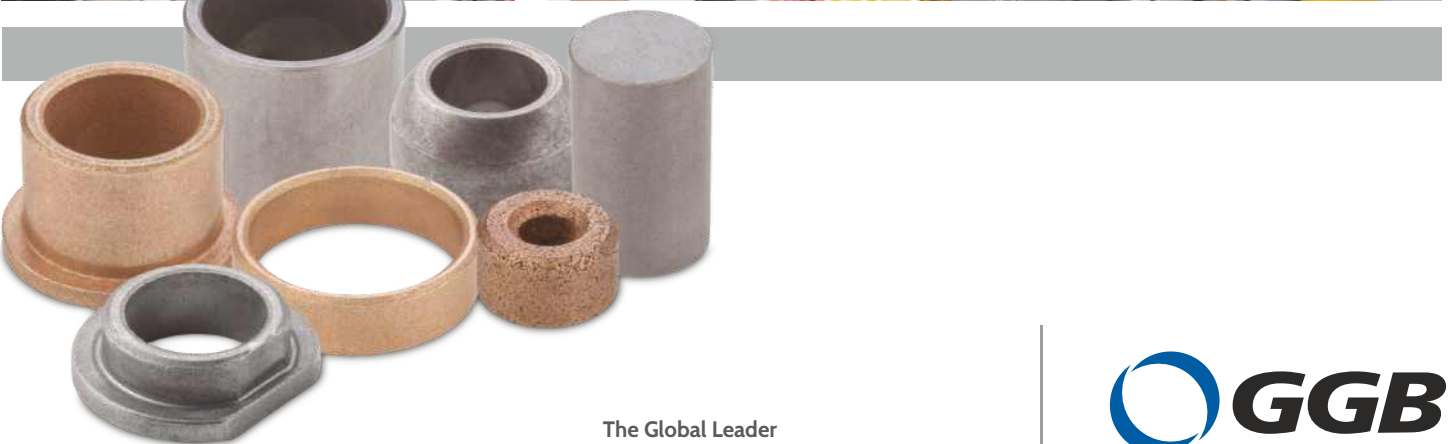

The Global Leader
in High Performance Bearing Solutions

 **GGB**
BEARING TECHNOLOGY

an EnPro Industries company

GGB Bearing Technology

GGB's history as the global leader in plain bearing technologies dates back more than 115 years, beginning with the founding of Glacier Antifriction Metal Company in 1899. GGB introduced the industry-leading DU® bearing in 1965. Since that time, GGB has continued to create innovative technologies and solutions that improve safety, performance and profitability in a wide range of markets. Today, our products can be found everywhere – from scientific vessels at the bottom of the ocean to racecars

speeding down the tarmac to jumbo jets slicing through the sky to the Curiosity rover exploring the surface of Mars.

Throughout our history, safety, excellence and respect have formed the foundational values for the entire GGB family. They are of paramount importance as we seek to maximize personal possibility, achieve excellence and establish open, creative work environments with the highest safety standards in the industry.

- **Safety:** GGB's deep-rooted culture of safety places a relentless focus on creating a secure, healthy work environment for all. A core value of GGB, safety is critically essential at all levels of business in order to achieve our goal of having the safest employees in the industry.
- **Excellence:** A world-class organization is built by fostering excellence throughout the company in all positions and functional areas. Our world-class manufacturing plants are certified in quality and excellence in the industry according

to ISO 9001, TS 16949, ISO 14001, ISO 50001 and OHSAS 18001, allowing us to access the industry's best practices while aligning our quality management system with global standards.

- **Respect:** We believe that respect is consistent with the growth of individuals and groups. Our teams work together with mutual respect regardless of background, nationality or function, embracing the diversity of people and learning from one another.

The GGB Advantage

With manufacturing facilities around the world, including cutting edge R&D facilities, flexible production platforms and extensive customer support networks, GGB offers unmatched technical expertise combined with razor sharp responsiveness and customized solutions. Our global presence and local logistics networks ensure our customers receive only the highest quality bearing solutions, in a timely manner and with extensive engineering support. **We don't just make products, we build partnerships. That's the GGB Advantage.**

Quality/Certification

Our world-class manufacturing plants in the United States, Brazil, China, Germany, France and Slovakia are **CERTIFIED IN QUALITY AND EXCELLENCE IN THE INDUSTRY** according to ISO 9001, TS 16949, ISO 14001, ISO 50001 and OHSAS 18001. This allows us to access the industry's best practices while aligning our quality management system with global standards.

For a complete listing of our certifications, please visit our website:

www.ggbearings.com/en/company/certificates

Content

GGB History	4	8	Standard Dimensions	21
1 Introduction	6	8.1	Bronze based GGB-BP25	
2 Applications	7		Cylindrical Bearings	21
2.1 Characteristics and Benefits		8.2	Iron based GGB-FP20	
of GGB Sinter Bearings	7		Cylindrical Bearings	22
2.2 Possible Applications	8	8.3	Bronze based GGB-BP25	
2.3 Available Designs	9		Flanged Bearings	23
3 Material Properties	9	8.4	Iron based GGB-FP20	
3.1 Material Structure	9		Flanged Bearings	24
3.2 Grade Selection	10	8.5	Cylindrical Blanks	24
3.3 Bronze based and		8.6	Solid Rod Blanks	25
Iron based Grades	10	8.7	Spherical Bearings	25
4 Lubrication	11		Bearing Application	
4.1 Lubricant Selection	11		Data Sheet	26
4.2 Principles of Lubrication	13		Product Information	27
5 Dimensions and				
Tolerances	15			
6 Bearing Installation	16			
7 Machining	18			
7.1 Machining of				
Self-lubricating Blanks	18			
7.2 De-impregnation and				
Re-impregnation of				
Self-lubricating Bearings	20			

The Highest Standards in Quality

Our world-class manufacturing plants in the United States, Brazil, China, Germany, France and Slovakia are certified in quality and excellence according to ISO 9001, TS 16949, ISO 14001, ISO 50001 and OHSAS 18001. This allows us to access the industry's best practices while aligning our management system with global standards.

For a complete listing of our certifications, please visit our website:
www.ggbearings.com/en/company/certificates



A Long History of Innovation

From our modest beginnings over 115 years ago, GGB grew through innovation and technical expertise to become the world's leading manufacturer of plain bearing solutions.

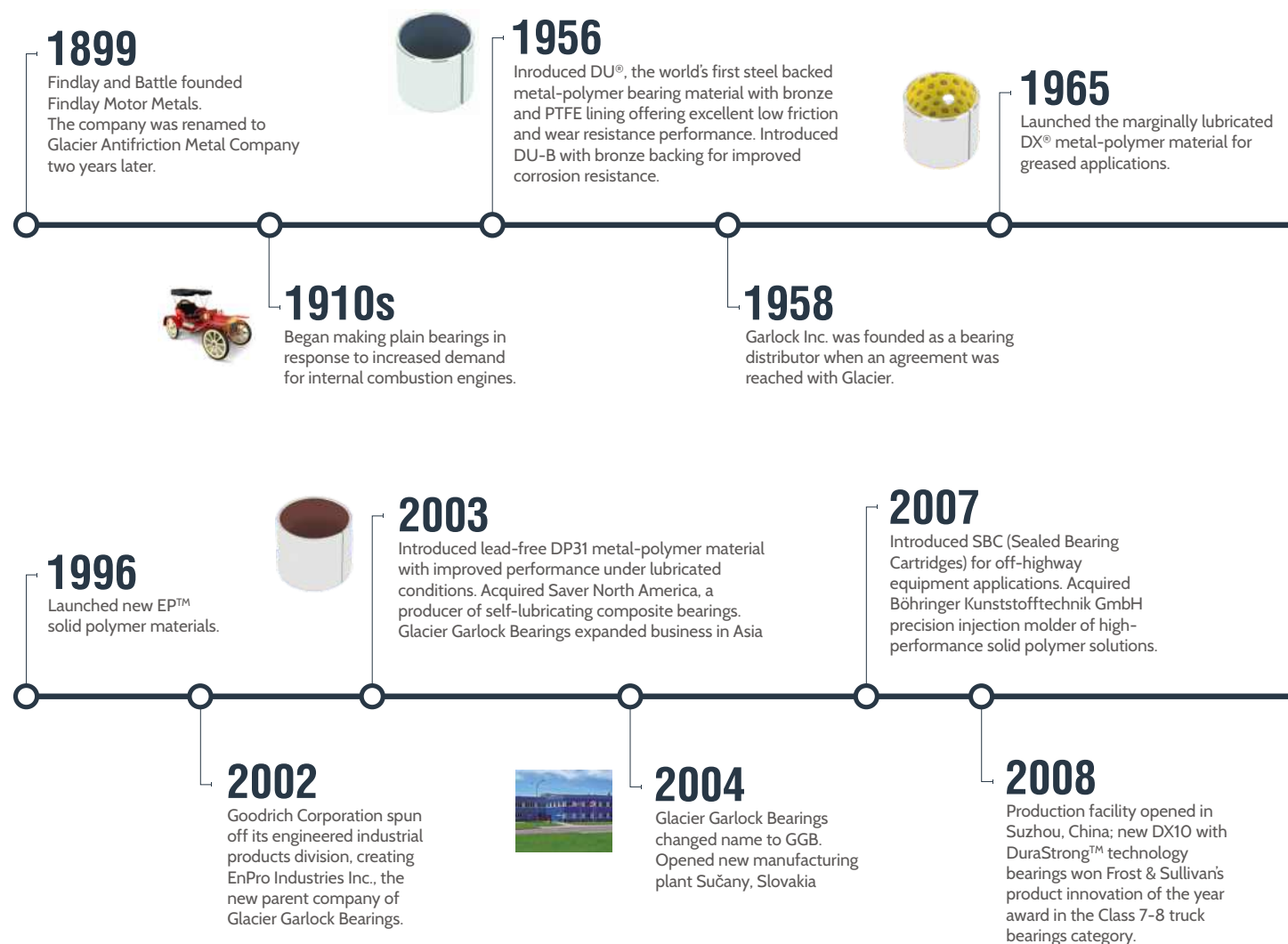



1974

Began continuous casting of the SICAL® range of aluminum alloys and high precision machining of bushing blocks in Dieuze, France.

1978

Introduced filament wound product range in the USA, including GAR-MAX®.



1995

Introduced lead-free steel backed DP4 metal-polymer material for automotive shock absorbers and other hydraulic applications. Introduced DP4-B with bronze backing for improved corrosion resistance.



1970s

Glacier licensed technology to a number of overseas bearing manufacturers. Licenses included: SIC (France), Garlock Bearings (USA).

1976

Glacier and Garlock Inc. established joint venture company Garlock Bearings Inc.



1986

Launched HI-EX® metal-polymer material, designed for high temperature applications.

2009

Filament-wound product range introduced to the European and Asian markets; GGB North America certified to AS9100B, the aerospace industry's standard for quality management systems.

2011

Acquired PI Bearing Technologies, now GGB Chicago, a producer of PICAL® aluminum alloy bushing blocks for demanding fluid power applications. GGB plants certified to OHS18001 for health and safety management systems.



2013

Launched new self-lubricating metallic bearing materials GGB-CSM® and GGB-CBM® as well as FLASH-CLICK® two-piece, double-flanged solid polymer bearings.

2010

Introduced lead-free DP10 and DP11 metal-polymer materials for superior performance under marginally lubricated and dry running conditions.



2012

DTS10® machinable metal-polymer bearings are launched for the fluid power and compressor markets. GGB bearings land on Mars aboard NASA's Curiosity rover.

2014

Series of self-lubricating sintered bronze and sintered iron bearings introduced, including GGB-BP25, GGB-FP20 and GGB-SO16.

Three plants mark milestone anniversaries: 40 years for Heilbronn, Germany and Dieuze, France and 10 years for Sučany, Slovakia.



2015

Introduced HPMB®, a fully machinable, made-to-order filament wound bearing material. Also introduced the lead-free GGB-SZ, for high specific loads with low-frequency, oscillating motion.

1 Introduction

The more and more demanding specifications of today's high performance equipment and systems require that the bearings operate not only under severe working conditions with minimal or no maintenance but that they also offer increased reliability and durability with lower operating costs.

Self-lubricating METAFRAM® sinter bronze and sinter iron bearings are designed for applications with high sliding speeds, requiring a low coefficient of friction, good corrosive or seizure resistance and suited to frequent stop starts, as well as for applications for which customary lubrication is not possible.

Furthermore, these bearings can replace already installed traditional lubricated bearings and offer solutions where customary lubrication is not possible.

With more than 100 years of experience and expertise in tribology, GGB offers, along with the widest range of lubricated and self-lubricating bearing products, a comprehensive technical and application engineering knowledge.

In this respect, our Application Engineers can assist you in:

- Choosing the right type of plain bearing for your application
- Design of the bearing according to standard dimensions or to customer specific requirements
- Establishing a life time estimate
- Assembly and installation recommendations

Thanks to our global production and supply network, we are able to offer customers throughout the world the industry's most extensive range of self-lubricating and prelubricated plain bearings for literally thousands of applications in scores of industries.

As a reliable supplier with flexible manufacturing, we can respond quickly to customer needs with either standard or customized products.

Our advanced R&D and testing facilities help us deliver comprehensive solutions and assure their performance, reliability and cost-effectiveness.

Our high performance bearing specialists have the experience and expertise to provide innovative solutions to even the most challenging applications.

2 Applications

The GGB sinter bearings from the METAFRAM® range are recommended for the following movements:

- Rotation
- Oscillation
- Linear

Other special material grades are available for specific requirements, for example:

- Higher speeds
- Higher loads

For more demanding requirements with lower or higher temperatures, increased speeds or loads, bearings can be impregnated with appropriate lubricants.

2.1 Characteristics and Benefits of GGB Sinter Bearings

Self-lubricating sinter bearings offer the following benefits depending on the grade of the metallic alloy and on the type of lubricant:

Performance

An extremely wide range of operating loads, speeds and temperatures:

- Dynamic loads from 6 to 75 MPa
- Linear speeds up to 8 m/s
- Operating temperatures from - 180°C to + 300°C

Suitable for use in a wide range of environments

- Marine environment
- Radio-active environments
- Contact with corrosive liquids or substances incompatible with oils
- Food preparation

Reduce of design and ownership costs

- Maintenance-free operation
- Lower cost compared to cast metal and machined bearings
- Complex designs and forms possible
- High dimensional accuracy
- Excellent surface finish
- Reduced weight compared to similar non-porous components

Safety

- Permanent oil film lubrication
- Low friction factor
- Quiet operation
- Good operation at low speed
- Corrosion resistance

2.2 Possible Applications

Industrial:

General assembly machinery, industrial vehicles, automation, farm machinery, sewing machines, bottling machines, key duplicating machines, electrical switchgears, mobility, toys, etc.

Household appliances:

Washing machines, fans, woodworking machines, vacuum cleaners, extractor fans, depilators, coffee machines, juicers, rostitserie, handtools, air conditioning, boilers, etc.

Home appliances:

Lawnmowers, roller shutters, office swivel chairs, locks, garage doors, awnings, sliding windows, hinges, furniture, gardening, etc.



2.3 Available Designs

Standard products

- Cylindrical plain bearings
- Flanged plain bearings
- Hollow and solid rod blanks for machining



Special parts on request

- Modified standard sizes
- Customized designs
- Sphericals



3 Material Properties

3.1 Material Structure

Sinter bronze and sinter iron self-lubricating bearings are made of two components which have different functions:

- The metallic alloy structure which supports and transfers the mechanical loads
- The liquid or solid lubricant which separates the two surfaces in relative motion and to reduce friction

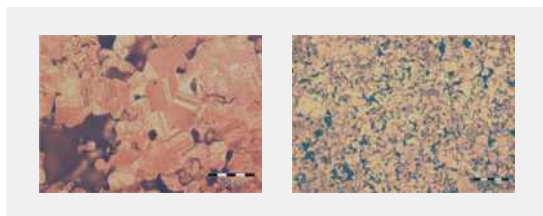

Fig. 1: Microsection of Sinter bronze (left) and Sinter iron

3.2 Grade Selection

The metallic structure of the self-lubricating bearing can be made from a wide range of bronze or iron based alloys. To select the proper grade for a given application, it is necessary to check the maximum values of the material characteristics in comparison with:

- Shaft linear speed - v
- Applied load - p
- $p v$ (load x speed) factor
- Shaft hardness and surface roughness and other parameters such as working temperature and type of lubrication, etc.

The following tables give the main physical and mechanical characteristics of GGB self-lubricating sinter bearings from the METAFRAM® range.

3.3 Bronze based and Iron based Grades

Standard material grades	Units	Bronze GGB-BP25	Iron alloy GGB-FP20	Iron alloy GGB-SO16 (blanks only)
Similar to AFNOR		FU-E10-62	FC10-U3-56	F50-U20-60
Similar to DIN 30910		Sint A50	Sint A10	N/A
Minimum density	g/cm ³	6.2	5.6	6.0
Maximum load p	MPa	20.0	45.0	120.0
- static		10.0	22.5	60.0
- dynamic				
Maximum sliding speed v	m/s	6.0	4.0	0.3
Maximum $p v$ factor	MPa x m/s	1.8	1.8	0.9
Operating temperatures	°C	- 5 / 90	- 5 / 90	0 / 105
Impregnation oil		MT100	MT100	METADOP
Minimum open porosity	%	23	20	16

Table 1: Standard material grades

Material Grade Selection

Bronze GGB-BP25	Iron alloy GGB-FP20	Iron alloy GGB-SO16
Good coefficient of friction	Recommended for medium or low speeds	Recommended for medium or low speeds
Good corrosion resistance	Good bearing strength	Good bearing strength
Recommended for high speeds	Recommended for high loads	Recommended for very high loads
Shaft surface finish $R_a \leq 0.6 \mu\text{m}$	Shaft surface finish $R_a \leq 0.2 \mu\text{m}$	Shaft surface finish $R_a \leq 0.2 \mu\text{m}$
Shaft hardness HB > 240	Shaft hardness HB > 355	Shaft hardness HB > 355

Table 2: Material grade selection

4 Lubrication

4.1 Lubricant Selection

Significant development and improvement of lubricants allow the use of METAFRAM® bearings in more and more applications and to comply with a wide range of working conditions in terms of temperature range and environment.

Under high loads

The use of lubricants using MoS₂ additives such as METADOP (Shell OM460 + MoS₂) is recommended.

Temperature range

These lubricants are suitable for a temperature range from - 40°C to 150°C.

Lubricants offering a wider temperature range are available on request.

Environment

The lubricant PE1152 is compliant with FDA (Food and Drug Administration) regulation.

Impregnation Lubricants

Producer	Designation	Type	Pour Point °C	Flash Point °C	Viscosity cSt		Temperature Range °C	
					at 40°C	at 100°C		
Shell	MT100	Mineral	- 9	255	100	11.5	- 5	90
Lubrilog	PE1116	Synthetic	- 50	255	65	9.5	- 40	150
Shell	OM460	High pressure	- 12	238	460	29	0	105
Lubrilog	PE1152	FDA	- 18	252	68	9	- 18	120

Table 3: most common oils. More oil grades are available on request for specific applications. For further information please contact our application engineering department.

Chemical and Physical Characteristics of Oil

Lubricants based on mineral oils comprise of a organic and inorganic compounds and their physical and chemical characteristics vary considerably.

A good understanding of the main characteristics hereafter mentioned is necessary to study difficult lubrication cases. The stability under oxidation and the viscosity are particularly important.

Stability under oxidation

Oxidation is a chemical reaction resulting from the combination of the oxygen contained in the air and with the mineral oil. The oxidized compounds can have an adverse effect on bearing operation. If soluble, they transform into acids and can generate corrosion on the metallic sliding counter face of the bearing. They can also form a resilient varnish which fills the the bearing porosities.

Acidity

Low acidity of the mineral oils is acceptable.

However, the acidity will increase when running at high temperature for long periods of time due to oxidation.

Viscosity

The viscosity of a liquid can be defined as a resistance to pouring, or as a measure of the friction between the molecules of the liquid in relative motion.

In the oil industry, the two common measurements are the kinematic viscosity in centistokes (cSt) or in Engler degrees.

Viscosity index (VI)

An increase in temperature leads to weaker intermolecular links inside the fluid and a decrease in viscosity. The viscosity index indicates the evolution of the viscosity with temperature. The higher the index, the less sensitive is the oil to increases in temperature.

Pour point

A mineral oil does not change directly from a liquid state to a solid state when it is cooled down. It exhibits a plastic intermediate phase due to the crystallization of paraffin and the freezing of the different elements.

The pour point is approximately the lowest temperature at which the pouring of the liquid can be observed.



4.2 Principles of Lubrication

Hydrodynamic Lubrication (high Speed - low Load)

Stationary position (1)

- The shaft is in contact with the bearing
- An oil meniscus is present at the contact point resulting from capillary forces.
- This oil meniscus assists in instant lubrication during startup.

Rotating shaft (2)

- Oil is drawn out of the bearing in the upper suction zone.
- Oil is driven around by the rotation of the shaft and forms an oil wedge which produces the necessary pressure to lift the shaft.
- Part of the circulating oil is forced, under the action of the pressure, in the pores of the bearing.

After operation (3)

- The oil is reabsorbed by the porous bearing, under the action of capillary forces.
- The oil meniscus remains at the contact point ready for instant lubrication startup.

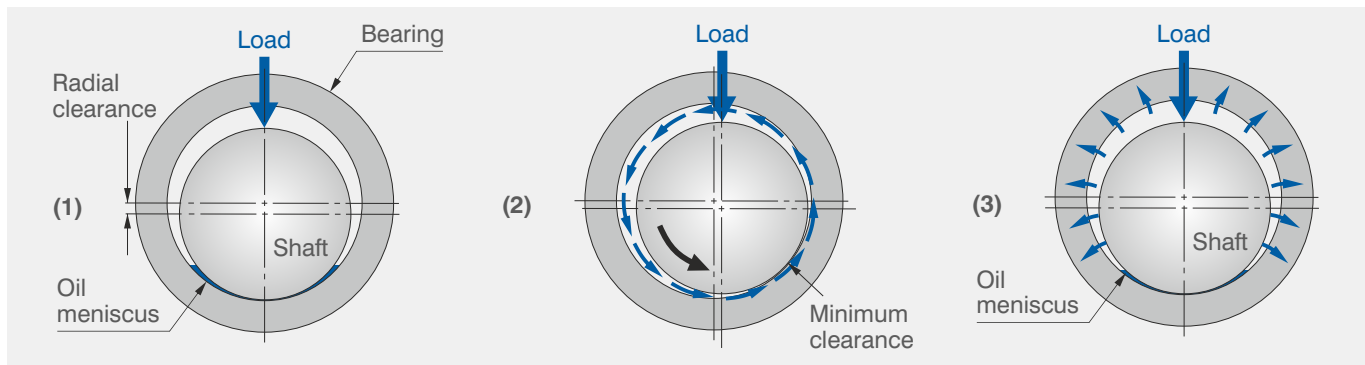

Boundary Lubrication (low Speed - high Load)

The features of this lubrication mode are as follows:

- Lubrication is provided by a lubricant film composed of molecular layers, with a strong force of adhesion to the surface and a low shear strength.
- Presence of metallic contact between the friction surfaces. Surface wear can be minimized using extreme pressure oils (eg. Shell OM460).

Solid Lubricants

In certain applications where the use of oil is not permitted (water presence, galvanic issues etc.) it is recommended to use solid lubricants such as molybdenum disulfide MoS₂, graphite Cg or fluoropolymers PTFE.

Designation	Max. Speed m/s	Max. Load MPa	pv Load x speed MPa x m/s	Temperature Range °C	Load v=0 MPa	Shaft Ra max µm	HB min.
GGB-BP25 + PTFE	1.0	10.0	0.3	- 180 / 180	20	0.3	240
GGB-FP20 + PTFE	1.0	22.5	0.3	- 180 / 180	45	0.3	300
GGB-BP25 + MoS ₂	0.1	10.0	0.1	- 180 / 180	20	0.3	355
GGB-FP20 + MoS ₂	0.1	22.5	0.1	- 180 / 300	45	0.3	355

Table 4: Grades proposed with solid lubricants.

5 Dimensions and Tolerances

The following tables indicate the size of the cylindrical or flanged bearings, and give the tolerances of the main dimensions.

In case reduced tolerances are required due to working requirements such as noise or vibration reduction, please contact your local GGB representative.

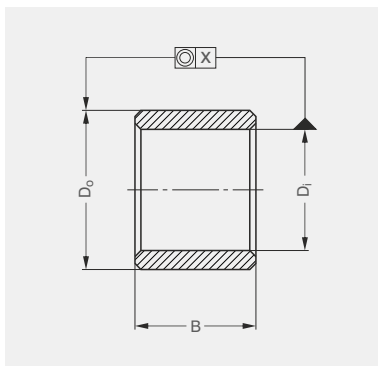

Cylindrical bearings		Tolerance D _i	Tolerance D _o	Tolerance B	Tolerance X
B/D _o < 1.5 and B/S ₃ < 15	D < 6	IT6	IT6	IT12	IT9
	6 < D ≤ 10	IT6	IT6		
	10 < D ≤ 18	IT6	IT6		
	18 < D ≤ 30	IT6	IT7		
1.5 < B < 2 and B/S ₃ < 20	30 < D ≤ 50	IT7	IT7	IT13	
	D < 6	IT6	IT6	IT12	IT9
	6 < D ≤ 10	IT6	IT6		
	10 < D ≤ 18	IT6	IT7		
18 < D ≤ 30	IT7	IT7			
30 < D ≤ 50	IT7	IT7	IT13		

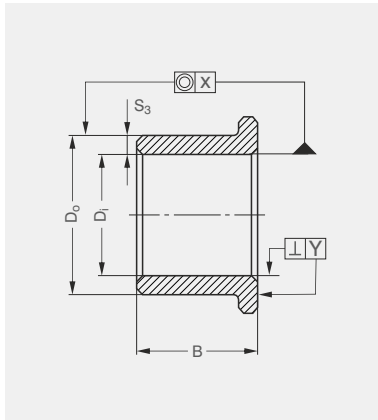

Flanged bearings		Tolerance D _i	Tolerance D _o	Tolerance B	Tolerance X	Tolerance Y
B/D _o < 0.5 and B/S ₃ < 5	D < 10	IT6	IT6	IT12	IT9	0.05
	10 < D ≤ 18	IT6	IT6			
	18 < D ≤ 30	IT6	IT6	IT13		0.07
0.5 < B D _o < 1 and B/S ₃ < 10	30 < D ≤ 50	IT7	IT7	IT12	IT9	0.05
	D < 10	IT6	IT6			
	10 < D ≤ 18	IT6	IT7	IT13		0.07
1 < B D _o < 2 and B/S ₃ < 15	18 < D ≤ 30	IT7	IT7	IT12	IT9	0.05
	30 < D ≤ 50	IT7	IT8			
	D < 10	IT6	IT7	IT13		0.07
10 < D ≤ 18	IT7	IT7				
18 < D ≤ 30	IT7	IT8				
30 < D ≤ 50	IT8	IT8				

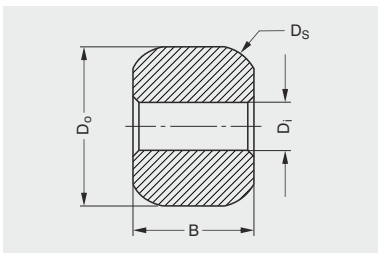

Spherical bearings	Tolerance D _i	Tolerance D _s	Tolerance D _o	Tolerance B	Concentricity D _i / D _o
	IT6	+/- 0.05	+/- 0.2	+/- 0.1	0.05

Minimum weight per bearing: 0.2 g Minimum thickness: 1 mm

B = bearing length (mm) D_i = bearing bore (mm)

D_o = bearing outer Ø (mm) D_s = sphere Ø (mm) S₃ = wall thickness: $\frac{D_o - D_i}{2}$ (mm)

Flange tolerances: Flange outside diameter: js13 - Flange thickness: js14

Surface Roughness

The surface roughness Ra of the inside diameter of a self-lubricated sinter bearing is between 1.2 µm and 3.2 µm, depending on the powder type (grain size) and on the density.

For standard grades (GGB-BP25, GGB-FP20), the surface roughness is between 2.5 µm and 3.2 µm.

6 Bearing Installation

Fitting with a stepped mandrel (Ground carbon steel – Surface finish: polished - Hardness > 60 RC)

The bearing is inserted into the housing with a press, using a stepped mandrel made to the recommended tolerances in order to avoid damage to the bearing and to obtain:

- A good guidance of the bearing which must be square to the housing
- The correct tolerance of the inside diameter of the bearing after assembly

Insertion forces

Estimated value with m6 mandrel, H7 housing with $R_a < 3.2 \mu\text{m}$ and housing considered as rigid*: 10 MPa (surface equal to $D \times B$ of the bearing)

*Housing considered as rigid: steel or cast iron housing with thickness at least 3 times the wall thickness of the bearing.

Steel housing (rigid)

The inner diameter tolerances of the assembled bearing and the final tolerances of the inner diameter of the bearing are determined assuming a rigid housing made of steel or eventually in cast iron.

Housing made of light alloys (aluminium, zamak etc.)

The interference fit is to be increased to compensate for the deformation of the housing. Tests are required to define the tolerances of the housing.

In certain conditions, housing ID / mandrel OD fits of J7 / s7 or K7 / s7 enable a H7 tolerance of the inner diameter of the bearing after assembly.

In the case of an assembly into light alloys and to minimize the risks due to creep deformation, it is sometimes necessary to design special shapes.

Shafts recommendations

Mechanical recommendations of steel shaft according to bearing grades:

For GGB-BP25 Sinter Bronze bearings:

- Steel hardness HB > 240
- Surface roughness $R_a < 0.6 \mu\text{m}$

For GGB-FP20 Sinter Iron bearings:

- Steel hardness HB > 355
- Surface roughness $R_a < 0.2 \mu\text{m}$

Mandrel

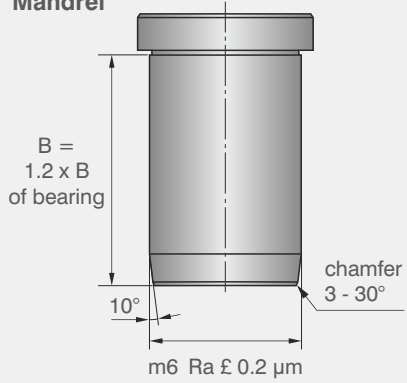

Bearing in free state

(Standard bearings)

Tolerance D_i : F7 (for $D_i > 50$ mm: F8)

Tolerance D_o : s7 (for $D_i > 50$ mm: s8)

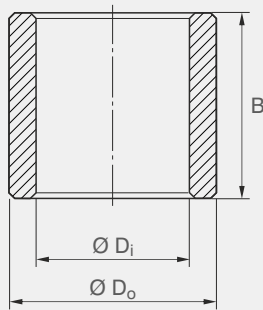

Steel housing (rigid)

Tolerance D_{housing} : H7

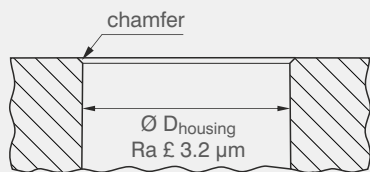

Bearing after assembly

(Standard bearings)

Tolerance D_i : H7 for $D_i > 50$ mm: H8

Tolerance D_i : H8 for flanged bearings

Tolerance D_o : H8

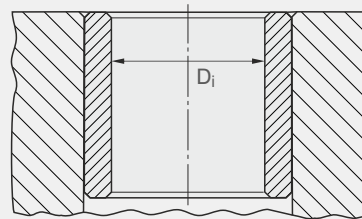

Shafts recommendations

Tolerance D: f7

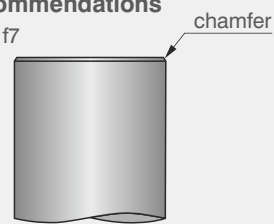

7 Machining

7.1 Machining of Self-lubricating Blanks

The sinter materials can be machined under the same conditions as for the corresponding solid metals. However, to protect the integrity of the porosities on the sliding surfaces (inner diameter or flange faces) it is recommended to apply the following specific machining conditions:

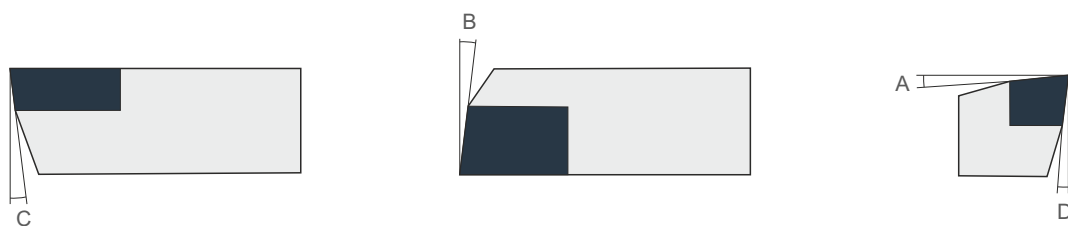

Machining Conditions for Bronze based GGB-BP25

Angle	Rough / Finish		Rough	Finish
A	0 - 3°	Tool grade	K10 / K20	K10 / K20
B	5 - 7°	Cutting speed (m/min)	120 - 200	140 - 200
C	5 - 7°	Feed rate (mm/rotation)	0.1 - 0.2	0.1 max
D	5 - 7°	Feed (mm)	£ 1.0	0.1 - 0.4

Machining Conditions for Iron based GGB-FP20 and GGB-SO16

Angle	Rough	Finish		Rough	Finish
A	3 - 7°	7 - 10	Tool grade	K10 / K20	K10 5015 (cermet*)
B	5°	10	Cutting speed (m/min)	140	160 200 - 250
C	5 - 7°	12 - 15	Feed rate (mm/rotation)	0.2 - 0.3	0.035 0.035 - 0.06
D	5 - 7°	12 - 15	Feed (mm)	1 - 5	0.3 - 0.5 0.3 - 0.5

* For increased productivity

Turning

Fixing

To avoid any deformation, especially for thin wall bearings, the machining of the inner diameters will be performed by fixing the part between grip clamps or soft jaws. For machining the outer diameter, the blanks must be fixed either on cantilevered mandrels or between centers mandrels (mandrel conicity 0.01%).

Facing and chamfering

After machining the faces with a very sharp tool, it is recommended to cut an internal and external chamfer in the range of 0.5 mm at 45°.

Drilling

When drilling through the bore, it is necessary to slow down the feed rate at the time of the release.

Bronze based GGB-BP25: no specific requirement.

Iron based GGB-FP20: HSS drill with 5% cobalt, with cutting speed between 25 and 30 m/min and feed rate of 0.1 to 0.3 mm/min.

Tapping

Bronze based GGB-BP25: no specific requirement.

Iron based GGB-FP20: nitrided taps with 5% cobalt, with cutting speed between 8 and 12 m/min.

Grinding

This machining type is not recommended for the finishing of the inner diameters. The reason is that the abrasive particles coming from the grinding wheels will be embedded in the sliding surface porosities and will accelerate the wear of the surfaces in motion.

Cutting Oil

The use of cutting oil is not necessary for the machining of the METAFRAM® blanks as the blank is impregnated with oil and therefore oil is present in the porosities of the sinter material. However, if the parts need to be cooled down, especially in the case of machining of high volumes, it is recommended to use the same oil as the one initially used for impregnation, or to use an air jet.

Any other cooling fluid should be avoided as it would risk to be incompatible with the original impregnation oil.

Re-impregnation after Use

All standard METAFRAM® blanks are supplied impregnated with mineral oils with a viscosity index higher than 95 cSt.

- To eliminate chips and dust, quickly wash the part with a volatile solvent such as Heptane or Biosane ECO 60R, then dry.
- Depending on the volume immerse the bearing for one or two hours in an oil bath at a temperature between 60°C and 120°C, depending on the oil viscosity.

However, to compensate the loss of oil during machining and handling, a re-impregnation is mandatory according to the following process:

- Cool down the part in this bath for a perfect saturation of porosities. It is recommended to use the same oil as the one used originally for the impregnation, or otherwise, engine oil type SAE 30.

Impregnation Oils

When the linear speed of the shaft is higher than 0.3 m/s, the standard impregnation oil is Shell Turbo T100 with a viscosity index equal to 98 cSt.

For rotational speeds lower than 0.3 m/s, for linear or angular movements, specific impregnation can be made on request (extreme pressure oil, molybdenum disulfide additives).

Control of Surface Porosities

In practice, it is accepted that any machining will slightly diminish the porosities of the sliding surfaces without impacting the performance of the self-lubricating material if the above machining instructions are respected. The control after machining of the residual porosities should be performed:

- Either by a comparative examination of the machined surface versus the non-machined surface under magnification.
- Or by a temperature increase of the machined part by 30°C on a heating source.

The large difference of coefficient of thermal expansion between the sinter metal and the impregnation oil generates the exudation of the lubricant.

The formation of a uniformly distributed oil film is the indication that the self-lubricating properties of the material are preserved.

7.2 De-impregnation and Re-impregnation of Self-lubricating Bearings

De-impregnation

To de-impregnate a self-lubricating bearing, the process is the following:

- Degrease and wash in appropriate solvent
- Eliminate the lubricant in an apparatus such as Soxhelt or in a furnace heated around 400°C for 40 minutes under a neutral atmosphere such as N₂, or with reducing agent such as N₂ + H₂

Re-impregnation

Simple method:

- Immerse during one hour the parts in an oil bath heated at a temperature between 60°C and 120°C, depending on oil viscosity.
- Let them cool down in an oil bath back to room temperature.
- Drain and dry the self-lubricating bearings.

The oil viscosity must be between 2 and 3 Engler degrees (10 to 20 cSt) at impregnation temperature.

8 Standard Dimensions

8.1 Bronze based GGB-BP25 Cylindrical Bearings

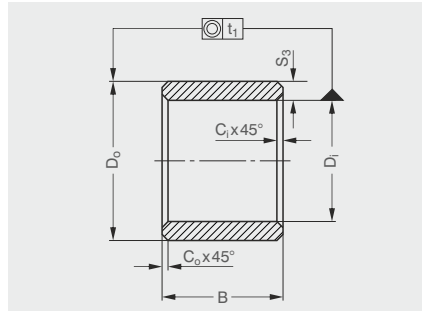

t_1 for $D_i \leq 20 \text{ mm} = 50 \text{ mm}$
 t_1 for $20 \text{ mm} < D_i \leq 35 \text{ mm} = 70 \text{ mm}$
 t_1 for $D_i > 35 = 100 \text{ mm}$
 chamfers $C = (0.1 \text{ to } 0.2) S_3$
 minimum 0.2 mm
 $B > 10 \pm 1\%$
 $B \leq 10 \pm 0.1 \text{ mm}$

Inside Ø D_i	Outside Ø D_o	Length B
2 ⁺¹⁶ / ₊₆	5 ⁺³¹ / ₊₁₉	2 - 3
3 ⁺¹⁶ / ₊₆	6 ⁺³¹ / ₊₁₉	4 - 6 - 10
4 ⁺²² / ₊₁₀	7 ⁺³⁸ / ₊₂₃	4 - 8 - 12
4 ⁺²² / ₊₁₀	8 ⁺³⁸ / ₊₂₃	4 - 8 - 12
5 ⁺²² / ₊₁₀	8 ⁺³⁸ / ₊₂₃	5 - 8 - 10 - 12 - 16
5 ⁺²² / ₊₁₀	9 ⁺³⁸ / ₊₂₃	4 - 5 - 8
6 ⁺²² / ₊₁₀	9 ⁺³⁸ / ₊₂₃	6 - 10 - 12 - 16
6 ⁺²² / ₊₁₀	10 ⁺³⁸ / ₊₂₃	6 - 10 - 12 - 16
6 ⁺²² / ₊₁₀	12 ⁺⁴⁶ / ₊₂₈	6 - 10 - 12 - 16
7 ⁺²³ / ₊₁₃	10 ⁺³⁸ / ₊₂₃	5 - 8 - 10
8 ⁺²³ / ₊₁₃	11 ⁺⁴⁶ / ₊₂₈	8 - 12 - 16 - 20
8 ⁺²³ / ₊₁₃	12 ⁺⁴⁶ / ₊₂₈	8 - 12 - 16 - 20
8 ⁺²³ / ₊₁₃	14 ⁺⁴⁶ / ₊₂₈	8 - 12 - 16 - 20
9 ⁺²³ / ₊₁₃	12 ⁺⁴⁶ / ₊₂₈	6 - 10 - 14
10 ⁺²³ / ₊₁₃	13 ⁺⁴⁶ / ₊₂₈	10 - 16 - 20 - 25
10 ⁺²³ / ₊₁₃	14 ⁺⁴⁶ / ₊₂₈	10 - 16 - 20 - 25
10 ⁺²³ / ₊₁₃	15 ⁺⁴⁶ / ₊₂₈	10 - 16 - 20 - 25
10 ⁺²³ / ₊₁₃	16 ⁺⁴⁶ / ₊₂₈	10 - 16 - 20 - 25
12 ⁺³⁴ / ₊₁₆	15 ⁺⁴⁶ / ₊₂₈	12 - 16 - 20 - 25
12 ⁺³⁴ / ₊₁₆	16 ⁺⁴⁶ / ₊₂₈	12 - 16 - 20 - 25
12 ⁺³⁴ / ₊₁₆	17 ⁺⁴⁶ / ₊₂₈	12 - 16 - 20 - 25
12 ⁺³⁴ / ₊₁₆	18 ⁺⁴⁶ / ₊₂₈	12 - 16 - 20 - 25
14 ⁺³⁴ / ₊₁₆	18 ⁺⁴⁶ / ₊₂₈	14 - 18 - 22 - 28

Inside Ø D_i	Outside Ø D_o	Length B
14 ⁺⁵⁶ / ₊₃₅	20 ⁺⁵⁶ / ₊₃₅	14 - 18 - 22 - 28
15 ⁺⁵⁶ / ₊₃₅	19 ⁺⁵⁶ / ₊₃₅	16 - 20 - 25 - 32
15 ⁺⁵⁶ / ₊₃₅	21 ⁺⁵⁶ / ₊₃₅	16 - 20 - 25 - 32
16 ⁺⁵⁶ / ₊₃₅	20 ⁺⁵⁶ / ₊₃₅	16 - 20 - 25 - 32
16 ⁺⁵⁶ / ₊₃₅	22 ⁺⁵⁶ / ₊₃₅	16 - 20 - 25 - 32
18 ⁺⁵⁶ / ₊₃₅	22 ⁺⁵⁶ / ₊₃₅	18 - 22 - 28 - 36
18 ⁺⁵⁶ / ₊₃₅	24 ⁺⁵⁶ / ₊₃₅	18 - 22 - 28 - 36
18 ⁺⁵⁶ / ₊₃₅	25 ⁺⁵⁶ / ₊₃₅	18 - 22 - 28 - 36
20 ⁺⁵⁶ / ₊₃₅	24 ⁺⁵⁶ / ₊₃₅	16 - 20 - 25 - 32
20 ⁺⁵⁶ / ₊₃₅	25 ⁺⁵⁶ / ₊₃₅	16 - 20 - 25 - 32
20 ⁺⁵⁶ / ₊₃₅	26 ⁺⁵⁶ / ₊₃₅	16 - 20 - 25 - 32
20 ⁺⁴¹ / ₊₂₀	27 ⁺⁵⁶ / ₊₃₅	16 - 20 - 25 - 32
20 ⁺⁴¹ / ₊₂₀	28 ⁺⁵⁶ / ₊₃₅	16 - 20 - 25 - 32
22 ⁺⁴¹ / ₊₂₀	27 ⁺⁵⁶ / ₊₃₅	18 - 22 - 28 - 36
22 ⁺⁴¹ / ₊₂₀	28 ⁺⁵⁶ / ₊₃₅	18 - 22 - 28 - 36
22 ⁺⁴¹ / ₊₂₀	29 ⁺⁵⁶ / ₊₃₅	18 - 22 - 28 - 36
25 ⁺⁴¹ / ₊₂₀	30 ⁺⁵⁶ / ₊₃₅	20 - 25 - 32 - 40
25 ⁺⁴¹ / ₊₂₀	32 ⁺⁶⁸ / ₊₄₃	20 - 25 - 32 - 40
28 ⁺⁴¹ / ₊₂₀	32 ⁺⁶⁸ / ₊₄₃	22 - 28 - 36 - 45
28 ⁺⁴¹ / ₊₂₀	33 ⁺⁶⁸ / ₊₄₃	22 - 28 - 36 - 45
28 ⁺⁴¹ / ₊₂₀	36 ⁺⁶⁸ / ₊₄₃	22 - 28 - 36 - 45
30 ⁺⁴¹ / ₊₂₀	38 ⁺⁶⁸ / ₊₄₃	24 - 30 - 38
32 ⁺⁵⁰ / ₊₂₅	38 ⁺⁶⁸ / ₊₄₃	20-25-33-40-50

Inside Ø D_i	Outside Ø D_o	Length B
32 ⁺⁵⁰ / ₊₂₅	40 ⁺⁶⁸ / ₊₄₃	20-25-33-40-50
35 ⁺⁵⁰ / ₊₂₅	44 ⁺⁶⁸ / ₊₄₃	22 - 28 - 35
35 ⁺⁵⁰ / ₊₂₅	45 ⁺⁶⁸ / ₊₄₃	25 - 35 - 40 - 50
36 ⁺⁵⁰ / ₊₂₅	42 ⁺⁶⁸ / ₊₄₃	22 - 28 - 36 - 45
36 ⁺⁵⁰ / ₊₂₅	45 ⁺⁶⁸ / ₊₄₃	22 - 28 - 36 - 45
38 ⁺⁵⁰ / ₊₂₅	44 ⁺⁶⁸ / ₊₄₃	25 - 35 - 45
40 ⁺⁵⁰ / ₊₂₅	46 ⁺⁶⁸ / ₊₄₃	25 - 32 - 40 - 50
40 ⁺⁵⁰ / ₊₂₅	50 ⁺⁶⁸ / ₊₄₃	25 - 32 - 40 - 50
45 ⁺⁵⁰ / ₊₂₅	51 ⁺⁹⁹ / ₊₅₃	28 - 36 - 45 - 56
45 ⁺⁵⁰ / ₊₂₅	55 ⁺⁹⁹ / ₊₅₃	35 - 45 - 55 - 65
45 ⁺⁵⁰ / ₊₂₅	56 ⁺⁹⁹ / ₊₅₃	28 - 36 - 45 - 56
50 ⁺⁵⁰ / ₊₂₅	56 ⁺⁹⁹ / ₊₅₃	32 - 40 - 50 - 63
50 ⁺⁵⁰ / ₊₂₅	60 ⁺⁹⁹ / ₊₅₃	32 - 40 - 50 - 63
55 ⁺⁷⁶ / ₊₃₀	65 ⁺⁹⁹ / ₊₅₃	40 - 55 - 70
60 ⁺⁷⁶ / ₊₃₀	70 ⁺¹⁰⁵ / ₊₅₉	50 - 60 - 90 - 120
60 ⁺⁷⁶ / ₊₃₀	72 ⁺¹⁰⁵ / ₊₅₉	50 - 60 - 70
60 ⁺⁷⁶ / ₊₃₀	80 ⁺¹⁰⁵ / ₊₅₉	90 - 120
63 ⁺⁷⁶ / ₊₃₀	70 ⁺¹⁰⁵ / ₊₅₉	40 - 50
70 ⁺⁷⁶ / ₊₃₀	80 ⁺¹⁰⁵ / ₊₅₉	90 - 120
80 ⁺⁹⁰ / ₊₃₆	100 ⁺¹²⁵ / ₊₇₁	120
100 ⁺⁹⁰ / ₊₃₆	120 ⁺¹³³ / ₊₇₉	120
110 ⁺⁹⁰ / ₊₃₆	125 ⁺¹⁵⁵ / ₊₉₂	120
125 ⁺¹⁰⁶ / ₊₄₃	150 ⁺¹⁶³ / ₊₁₀₀	120

All tolerances in μm

Cylindrical bushes with H7 (H8 for $\varnothing \geq 50 \text{ mm}$) and flanged bushes with H8 inner diameter tolerance after being pressed into a housing with an inner diameter with H7 tolerance using a mandrel with m6 outer diameter tolerance.

Delivery tolerance in accordance with ISO standard F7/s7 for cylindrical bushes (for $D_i > 50 \text{ mm}$ and $D_o > 50 \text{ mm}$ F8/s8) and F8/s8 for flanged bushes.



8.2 Iron based GGB-FP20 Cylindrical Bearings

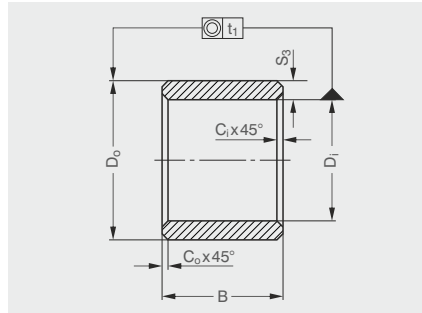

t_1 for $D_i \leq 20 \text{ mm} = 50 \text{ mm}$
 t_1 for $20 \text{ mm} < D_i \leq 35 \text{ mm} = 70 \text{ mm}$
 t_1 for $D_i > 35 = 100 \text{ mm}$
 chamfers $C = (0.1 \text{ to } 0.2) S_3$
 minimum 0.2 mm
 $B > 10 \pm 1\%$
 $B \leq 10 \pm 0.1 \text{ mm}$

Inside Ø D_i	Outside Ø D_o	Length B
3 +16 +6	6 +31 +19	4 - 10
4 +22 +10	8 +38 +23	8
6 +22 +10	9 +38 +23	6 - 10 - 12 - 16
6 +22 +10	10 +38 +23	6 - 10 - 16
6 +22 +10	12 +46 +28	6
8 +23 +13	11 +46 +28	8 - 12 - 16
8 +23 +13	12 +46 +28	8 - 12 - 16 - 20
10 +23 +13	13 +46 +28	10 - 20 - 25
10 +23 +13	14 +46 +28	10 - 16 - 20
10 +23 +13	15 +46 +28	10
12 +34 +16	15 +46 +28	12 - 16 - 20
12 +34 +16	16 +46 +28	12 - 16 - 20 - 25
12 +34 +16	17 +46 +28	12
14 +34 +16	18 +46 +28	14 - 18 - 22

Inside Ø D_i	Outside Ø D_o	Length B
14 +34 +16	20 +56 +35	14 - 28
15 +34 +16	19 +56 +35	16 - 20
16 +34 +16	20 +56 +35	16 - 20 - 25 - 32
16 +34 +16	22 +56 +35	16 - 20 - 25
18 +34 +16	22 +56 +35	18 - 22
18 +34 +16	24 +56 +35	22
20 +41 +20	24 +56 +35	16 - 20 - 25 - 32
20 +41 +20	26 +56 +35	16 - 20 - 25 - 32
22 +41 +20	27 +56 +35	18 - 22
25 +41 +20	30 +56 +35	20 - 25 - 32
25 +41 +20	32 +68 +43	20 - 25 - 32
30 +41 +20	38 +68 +43	24 - 30 - 38
32 +50 +25	38 +68 +43	32
35 +50 +25	44 +68 +43	22 - 28 - 35

Inside Ø D_i	Outside Ø D_o	Length B
36 +50 +25	42 +68 +43	22
40 +50 +25	46 +68 +43	25 - 32 - 40
40 +50 +25	50 +68 +43	25 - 32 - 40 - 50
45 +50 +25	51 +99 +53	28 - 45
45 +50 +25	55 +99 +53	35
45 +50 +25	56 +99 +53	36
50 +50 +25	56 +99 +53	32
50 +50 +25	60 +99 +53	30 - 50
60 +76 +30	70 +105 +59	60 - 90
70 +76 +30	80 +105 +59	120
80 +90 +36	100 +125 +71	120
100 +90 +36	120 +133 +79	120

All tolerances in μm

Cylindrical bushes with H7 (H8 for $\varnothing \neq 50 \text{ mm}$) and flanged bushes with H8 inner diameter tolerance after being pressed into a housing with an inner diameter with H7 tolerance using a mandrel with m6 outer diameter tolerance.

Delivery tolerance in accordance with ISO standard F7/s7 for cylindrical bushes (for $D_i > 50 \text{ mm}$ and $D_o > 50 \text{ mm}$ F8/s8) and F8/s8 for flanged bushes.

8.3 Bronze based GGB-BP25 Flanged Bearings

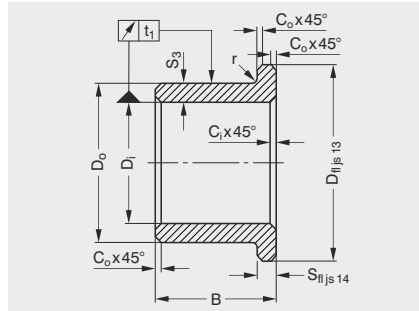

t_1 for $D_i \leq 20 \text{ mm} = 60 \text{ mm}$
 t_1 for $20 \text{ mm} < D_i \leq 35 \text{ mm} = 80 \text{ mm}$
 t_1 for $D_i > 35 = 100 \text{ mm}$
 chamfers $C = (0.1 \text{ to } 0.2) S_3$
 minimum $0,2 \text{ mm}$
 $r = \max. 0.3 \times S_3$
 $B > 10 \pm 1\%$
 $B \leq 10 \pm 0.1 \text{ mm}$

Inside Ø D_i	Outside Ø D_o	Flange Ø D_{fl}	Flange Thickness S_{fl}	Length B		
3	+20 +6	6	+37 +19	9	1,5	4 - 6 - 10
4	+28 +10	8	+45 +23	12	2	4 - 8 - 12
6	+28 +10	10	+45 +23	14	2	6 - 10 - 16
8	+35 +13	12	+55 +28	16	2	8 - 12 - 16
9	+35 +13	14	+55 +28	19	2,5	6 - 10 - 14
10	+35 +13	13	+55 +28	16	1,5	10 - 16 - 20
10	+35 +13	15	+55 +28	20	2,5	10 - 16 - 20
10	+35 +13	16	+55 +28	22	3	9 - 10 - 16
12	+43 +16	15	+55 +28	18	1,5	12 - 16 - 20
12	+43 +16	17	+55 +28	22	2,5	12 - 16 - 20 - 25
12	+43 +16	18	+55 +28	24	3	8 - 12 - 20
14	+43 +16	18	+55 +28	22	2	14 - 18 - 22
14	+43 +16	20	+68 +35	26	3	14 - 18 - 22 - 28
15	+43 +16	19	+68 +35	23	2	16 - 20 - 25
15	+43 +16	21	+68 +35	27	3	16 - 20 - 25 - 32
16	+43 +16	20	+68 +35	24	2	16 - 20 - 25
16	+43 +16	22	+68 +35	28	3	16 - 20 - 25 - 32
18	+43 +16	22	+68 +35	26	2	18 - 22 - 28
18	+43 +16	24	+68 +35	30	3	18 - 22 - 28
20	+53 +20	24	+68 +35	28	2	16 - 20 - 25

Inside Ø D_i	Outside Ø D_o	Flange Ø D_{fl}	Flange Thickness S_{fl}	Length B		
20	+53 +20	26	+68 +35	32	3	16 - 20 - 25 - 32
22	+53 +20	27	+68 +35	32	2,5	18 - 22 - 28
22	+53 +20	28	+68 +35	34	3	15 - 20 - 25 - 30
22	+53 +20	29	+68 +35	36	3,5	18 - 22 - 28 - 36
25	+53 +20	30	+68 +35	35	2,5	20 - 25 - 32
25	+53 +20	32	+82 +43	39	3,5	20 - 25 - 32
28	+53 +20	33	+82 +43	38	2,5	22 - 28 - 36
28	+53 +20	36	+82 +43	44	4	22 - 28 - 36
30	+53 +20	38	+82 +43	46	4	20 - 25 - 30
32	+64 +25	38	+82 +43	44	3	20 - 25 - 32
32	+64 +25	40	+82 +43	48	4	20 - 25 - 30 - 32
36	+64 +25	42	+82 +43	48	3	22 - 28 - 36
36	+64 +25	45	+82 +43	54	4,5	22 - 28 - 36
40	+64 +25	46	+82 +43	52	3	25 - 32 - 40
40	+64 +25	50	+82 +43	60	5	25 - 32 - 40
45	+64 +25	51	+99 +53	57	3	28 - 36 - 45
45	+64 +25	56	+99 +53	67	5,5	28 - 36 - 45
50	+64 +25	56	+99 +53	62	3	32 - 40 - 50
50	+64 +25	60	+99 +53	70	5	32 - 40 - 50
60	+64 +25	70	+105 +59	80	5	50 - 60

All tolerances in μm

Cylindrical bushes with H7 (H8 for $\text{Ø} \leq 50 \text{ mm}$) and flanged bushes with H8 inner diameter tolerance after being pressed into a housing with an inner diameter with H7 tolerance using a mandrel with m6 outer diameter tolerance.

Delivery tolerance in accordance with ISO standard F7/s7 for cylindrical bushes (for $D_i > 50 \text{ mm}$ and $D_o > 50 \text{ mm}$ F8/s8) and F8/s8 for flanged bushes.

8.4 Iron based GGB-FP20 Flanged Bearings

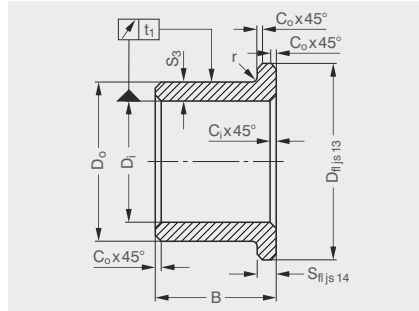

t_1 for $D_i \leq 20 \text{ mm} = 60 \text{ mm}$
 t_1 for $20 \text{ mm} < D_i \leq 35 \text{ mm} = 80 \text{ mm}$
 t_1 for $D_i > 35 = 100 \text{ mm}$
 chamfers $C = (0.1 \text{ to } 0.2) S_3$
 minimum 0.2 mm
 $r = \max. 0.3 \times S_3$
 $B > 10 \pm 1\%$
 $B \leq 10 \pm 0.1 \text{ mm}$

Inside Ø D_i	Outside Ø D_o	Flange Ø D_{fl}	Flange Thickness S_{fl}	Length B		
3	+20 +6	6	+28 +10	9	1,5	4
6	+28 +10	10	+45 +23	14	2	6 - 10 - 16
8	+35 +13	12	+55 +28	16	2	8 - 12 - 16
10	+35 +13	13	+55 +28	16	1,5	10 - 16
10	+35 +13	15	+55 +28	20	2,5	10 - 16 - 20
12	+43 +16	15	+55 +28	18	1,5	12 - 16 - 20
12	+43 +16	17	+55 +28	22	2,5	12 - 16
14	+43 +16	18	+55 +28	22	2	14 - 18 - 22
16	+43 +16	20	+68 +35	24	2	16 - 20
16	+43 +16	22	+68 +35	28	3	16 - 20 - 25
18	+43 +16	24	+68 +35	30	3	18 - 22

Inside Ø D_i	Outside Ø D_o	Flange Ø D_{fl}	Flange Thickness S_{fl}	Length B		
20	+53 +20	24	+68 +35	28	2	16 - 20 - 25
20	+53 +20	26	+68 +35	32	3	16 - 20 - 25
22	+53 +20	29	+68 +35	36	3,5	18 - 22 - 28 - 36
25	+53 +20	30	+68 +35	35	2,5	20 - 32
25	+53 +20	32	+82 +43	39	3,5	25 - 32
30	+53 +20	38	+82 +43	46	4	30
32	+64 +25	40	+82 +43	48	4	20 - 32
36	+64 +25	45	+82 +43	51	4,5	22 - 36
40	+64 +25	50	+82 +43	60	5	25 - 32 - 40
50	+64 +25	60	+99 +53	70	5	50
60	+76 +30	70	+105 +59	80	5	50 - 60

All tolerances in μm

Cylindrical bushes with H7 (H8 for $\varnothing \geq 50 \text{ mm}$) and flanged bushes with H8 inner diameter tolerance after being pressed into a housing with an inner diameter with H7 tolerance using a mandrel with m6 outer diameter tolerance.

Delivery tolerance in accordance with ISO standard F7/s7 for cylindrical bushes (for $D_i > 50 \text{ mm}$ and $D_o > 50 \text{ mm}$ F8/s8) and F8/s8 for flanged bushes.

8.5 Cylindrical Blanks

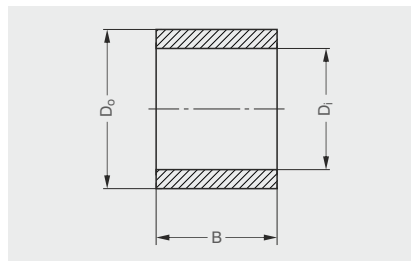

Inside Ø D_i	GGB-BP25 Outside Ø D_o	Length B			
38	+0,8 -0,8	70	+1,5 -1,5	120	+4,0 -0,0
45	+0,8 -0,8	105	+1,5 -1,5	120	+4,0 -0,0
80	+0,8 -0,8	145	+2,0 -2,0	120	+4,0 -0,0
80	+0,8 -0,8	175	+2,0 -2,0	120	+4,0 -0,0
85	+1,5 -1,5	105	+2,0 -2,0	120	+4,0 -0,0

Inside Ø D_i	GGB-FP20 Outside Ø D_o	Length B			
38	+0,8 -0,8	70	+1,5 -1,5	120	+4,0 -0,0
45	+0,8 -0,8	105	+1,5 -1,5	120	+4,0 -0,0
80	+0,8 -0,8	145	+2,0 -2,0	120	+4,0 -0,0
80	+0,8 -0,8	175	+2,0 -2,0	120	+4,0 -0,0
85	+1,5 -1,5	105	+2,0 -2,0	120	+4,0 -0,0

Inside Ø D_i	GGB-S016 Outside Ø D_o	Length B			
38	+0,8 -0,8	70	+1,5 -1,5	120	+4,0 -0,0
45	+0,8 -0,8	105	+1,5 -1,5	120	+4,0 -0,0
80	+0,8 -0,8	145	+2,0 -2,0	120	+4,0 -0,0
80	+0,8 -0,8	175	+2,0 -2,0	120	+4,0 -0,0
85	+1,5 -1,5	105	+2,0 -2,0	120	+4,0 -0,0

All tolerances in μm

8.6 Solid Rod Blanks

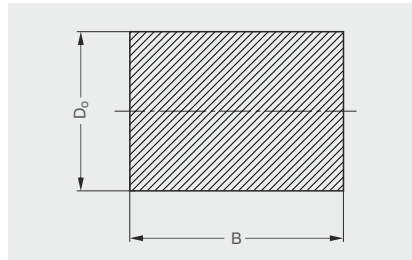

GGB-BP25		Length B	
Outside Ø D _o			
20	+0,8 -0,8	40	+4,0 +0,0
30	+0,8 -0,8	50	+4,0 +0,0
45	+0,8 -0,8	90	+4,0 +0,0
54	+0,8 -0,8	110	+4,0 +0,0
70	+0,8 -0,8	120	+4,0 +0,0
105	+0,8 -0,8	120	+4,0 +0,0
145	+1,5 -1,5	120	+4,0 +0,0

GGB-FP20		Length B	
Outside Ø D _o			
20	+0,8 -0,8	40	+4,0 +0,0
30	+0,8 -0,8	50	+4,0 +0,0
45	+0,8 -0,8	90	+4,0 +0,0
54	+0,8 -0,8	110	+4,0 +0,0
70	+0,8 -0,8	120	+4,0 +0,0
105	+0,8 -0,8	120	+4,0 +0,0
145	+1,5 -1,5	120	+4,0 +0,0

GGB-S016		Length B	
Outside Ø D _o			
20	+0,8 -0,8	40	+4,0 +0,0
30	+0,8 -0,8	50	+4,0 +0,0
45	+0,8 -0,8	90	+4,0 +0,0
54	+0,8 -0,8	110	+4,0 +0,0
70	+0,8 -0,8	120	+4,0 +0,0
105	+0,8 -0,8	120	+4,0 +0,0
145	+1,5 -1,5	120	+4,0 +0,0

All tolerances in mm

8.7 Spherical Bearings

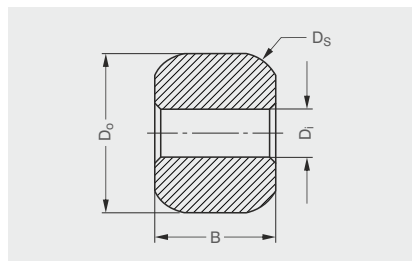

Inside Ø D _i	GGB-BP25 / GGB-FP20		Length B				
	Spherical Ø D _s	Outside Ø D _o					
4	+0,012 +0,0	10	+0,05 -0,05	9,5	+0,2 -0,2	8	+0,1 -0,1
5	+0,012 +0,0	13	+0,05 -0,05	12,5	+0,2 -0,2	10	+0,1 -0,1
6	+0,012 +0,0	13	+0,05 -0,05	12,6	+0,2 -0,2	8	+0,1 -0,1
6	+0,012 -0,0	15	+0,05 -0,05	14,5	+0,2 -0,2	12	+0,1 -0,1
6	+0,012 +0,0	16	+0,05 -0,05	15,5	+0,2 -0,2	12,5	+0,1 -0,1
7	+0,012 +0,0	17	+0,05 -0,05	16,5	+0,2 -0,2	14	+0,1 -0,1
8	+0,012 +0,0	16	+0,05 -0,05	15,5	+0,2 -0,2	12,5	+0,1 -0,1

All tolerances in mm

Bearing Application Data Sheet

Not sure which GGB part fits your application requirements? Go to ggbpartfinder.com to complete a Bearing Application Data Sheet online, and one of our GGB bearing specialists will reach out to you with recommended options that meet your application requirements. You can also complete the form below and share it with your GGB sales person or distributor representative.

DATA FOR BEARING DESIGN CALCULATION

New Design Existing Design

Application: _____

Project / No.: _____ Quantity: _____

DIMENSIONS (mm)

Inside diameter	D_i
Outside diameter	D_o
Length	B
Outer ring length	B_F
Flange diameter	D_{fi}
Spherical diameter	D_s
Wall thickness	S_T
Length of slideplate	L
Width of slideplate	W
Thickness of slideplate	S_s

LOAD

Radial load F	static [N]
	dynamic [N]
Axial load F	static [N]
	dynamic [N]
Specific load p	radial [MPa]
	axial [MPa]

MOVEMENT

Rotational speed	N [1/min]
Speed	U [m/s]
Length of stroke	L_s [mm]
Frequency of stroke	[1/min]
Oscillating cycle	ϕ [°]
Osc. frequency	N_{osz} [1/min]

MATING SURFACE

Material	
Hardness	HB/HRC
Surface finish	Ra [μ m]

CUSTOMER INFORMATION

Company _____
 Street _____
 City / State / Province / Post Code _____
 Telephone _____ Fax _____
 Name _____
 Email Address _____ Date _____

FITS & TOLERANCES

Shaft	D_j
Bearing housing	D_H

OPERATING ENVIRONMENT

Ambient temperature T_{amb} [°]

Housing with good heating transfer properties

Light pressing or insulated housing with poor heat transfer properties

Non metal housing with poor heat transfer properties

Alternate operation in water and dry

LUBRICATION

Dry

Continuous lubrication

Process fluid lubrication

Initial lubrication only

Hydrodynamic conditions

Process fluid	
Lubricant	
Dynamic viscosity	η

SERVICE HOURS PER DAY

Continuous operation	
Intermittent operation	
Operating time	
Days per year	

SERVICE LIFE

Required service life	L_H [h]
-----------------------	-----------

BEARING TYPE:

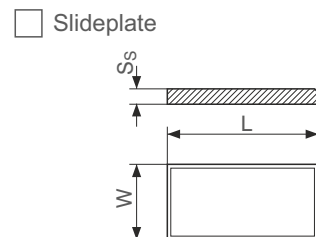
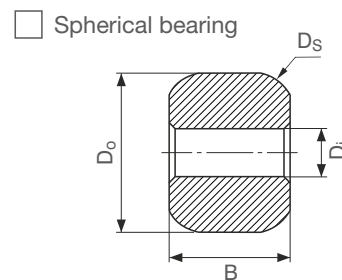
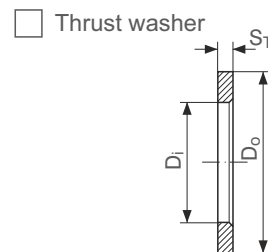
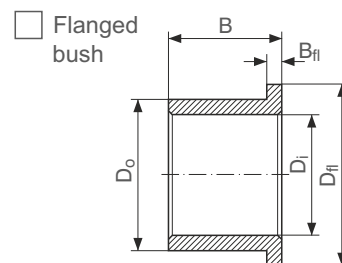
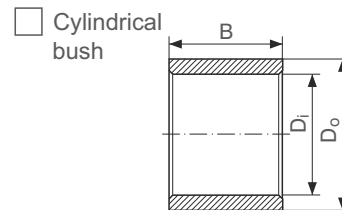

- Special parts (sketch)
- Rotational movement
- Steady load
- Rotating load
- Oscillating movement
- Linear movement

Product Information

GGB gives an assurance that the products described in this document have no manufacturing errors or material deficiencies.

The details set out in this document are registered to assist in assessing the material's suitability for the intended use. They have been developed from our own investigations as well as from generally accessible publications. They do not represent any assurance for the properties themselves.

Unless expressly declared in writing, GGB gives no warranty that the products described are suited to any particular purpose or specific operating circumstances. GGB accepts no liability for any losses, damages or costs however they may arise through direct or indirect use of these products.

GGB's sales and delivery terms and conditions, included as an integral part of quotations, stock and price lists, apply absolutely to all business conducted by GGB. Copies can be made available on request.

Products are subject to continual development. GGB retains the right to make specification amendments or improvements to the technical data without prior announcement.

Edition 2016 (This edition replaces earlier editions which hereby lose their validity).

Statement Regarding Lead Content in GGB Products & EU Directive Compliance

GGB is committed to adhering to all U.S., European and international standards and regulations with regard to lead content. We have established internal processes that monitor any changes to existing standards and regulations, and we work collaboratively with customers and distributors to ensure that all requirements are strictly followed. This includes RoHS and REACH guidelines.

GGB makes it a top priority to operate in an environmentally conscious and safe manner. We follow numerous industry best practices, and are committed to meeting or exceeding a variety of internationally recognized standards for emissions control and workplace safety.

Each of our global locations has management systems in place that adhere to ISO TS 16949, ISO 9001, ISO 14001, ISO 50001 and OHSAS 18001 quality regulations.

All of our certificates can be found here: <http://www.ggbearings.com/en/company/certificates>. A detailed explanation of our commitment to REACH and RoHS directives can be found at www.ggbearings.com/en/company/quality-and-environment.





an EnPro Industries company

The Global Leader in High Performance Bearing Solutions

GGB North America

700 Mid Atlantic Parkway
Thorofare, New Jersey, 08086 USA
Tel. +1-856-848-3200 • Fax +1-856-848-5115
email: usa@ggbearings.com • www.ggbearings.com



IN119ENG02-16USA